

Parking Pallet PE/PH

Page 1
Dimensions
Car data

Page 2
Examples
Drive
Evenness

Page 3
Drive
Rails
Incline

Page 4
Access
Electric
Technical
data

Page 5
To be performed by the customer
Description

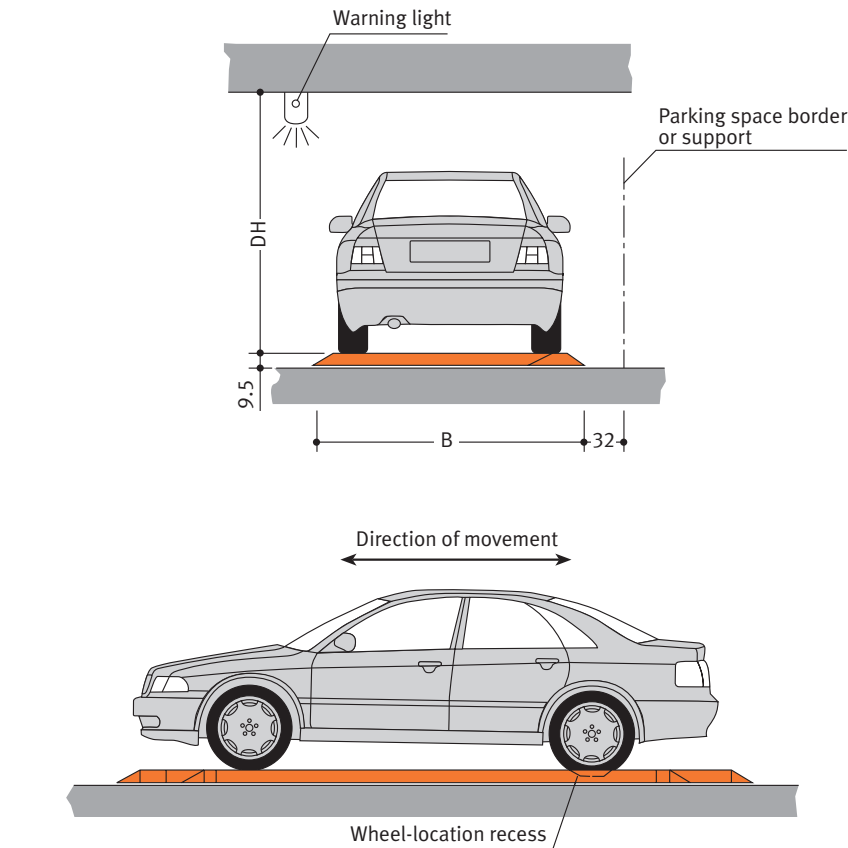

Parking Pallet PE

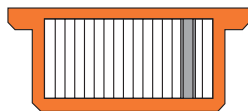

Parking Pallet PH

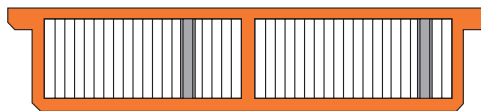

Building law requirements

According to the German Building Code parking spaces on longitudinally shifting parking pallets are only permitted if the following requirements are met:

- Next to the parking pallets a remaining driving lane width of 275 cm minimum must be maintained.
- Parking pallets must not be installed before power-driven parking systems.
- In case of two-way traffic in the driving lane no through traffic is permitted.
- The parking pallets must be traversable on all sides.
- Walkable areas must provide headroom of 200 cm. Make sure to observe the ventilation systems, bearers or other installations. The parking pallets have a height of 10 cm.

Product Data Parking Pallet PE/PH longitudinally shifting



Dimensions:

All space requirements are minimum finished dimensions. Tolerances for space requirements $^{+3}_0$. Dimensions in cm.

Top edge finished floor:

Tolerances for the evenness of the carriage-way must be strictly complied with in accordance with DIN (= German Industrial Standard) No. 18202, table 3, line 3!

| Type | No. of vehicles | DH |
|------|-----------------|----------------------------|
| PE | 1 | acc. to local requirements |
| PH | 2 | acc. to local requirements |

Standard type

| Type | W | L | Shift. length |
|------|-----|------|---------------|
| PE | 215 | 500 | 470 |
| PH | 215 | 1000 | 970 |

Exclusive type

| Type | W | L | Shift. length |
|------|-----|------|---------------|
| PE | 245 | 530 | 500 |
| PH | 245 | 1060 | 1030 |

Suitable for:

Standard passenger car and station wagon.

Car dimensions

| | |
|--------|--------------------|
| Length | max. 5.00 m |
| Width | max. 1.90 m |
| Height | 10 cm less than DH |

Standard type

| | |
|------------|--------------|
| Weight | max. 2000 kg |
| Wheel load | max. 500 kg |

Exclusive type

| | |
|------------|--------------|
| Weight | max. 2300 kg |
| Wheel load | max. 575 kg |

Standard passenger cars are vehicles without any sports design such as spoilers, low-profile tyres etc.

KLAUS
multiparking

Klaus Multiparking GmbH
Hermann-Krum-Straße 2
D-88319 Aitrach

Phone +49-75 65-5 08-0

Fax +49-75 65-5 08-88

E-Mail info@multiparking.com

Internet www.multiparking.com

- Page 1
Dimensions
Car data
- Page 2
Examples
Drive
Evenness
- Page 3
Drive
Rails
Incline
- Page 4
Access
Electric
Technical
data
- Page 5
To be performed
by the customer
Description

Examples: Longitudinal Pallets with Above-Floor Drive (Drive S)

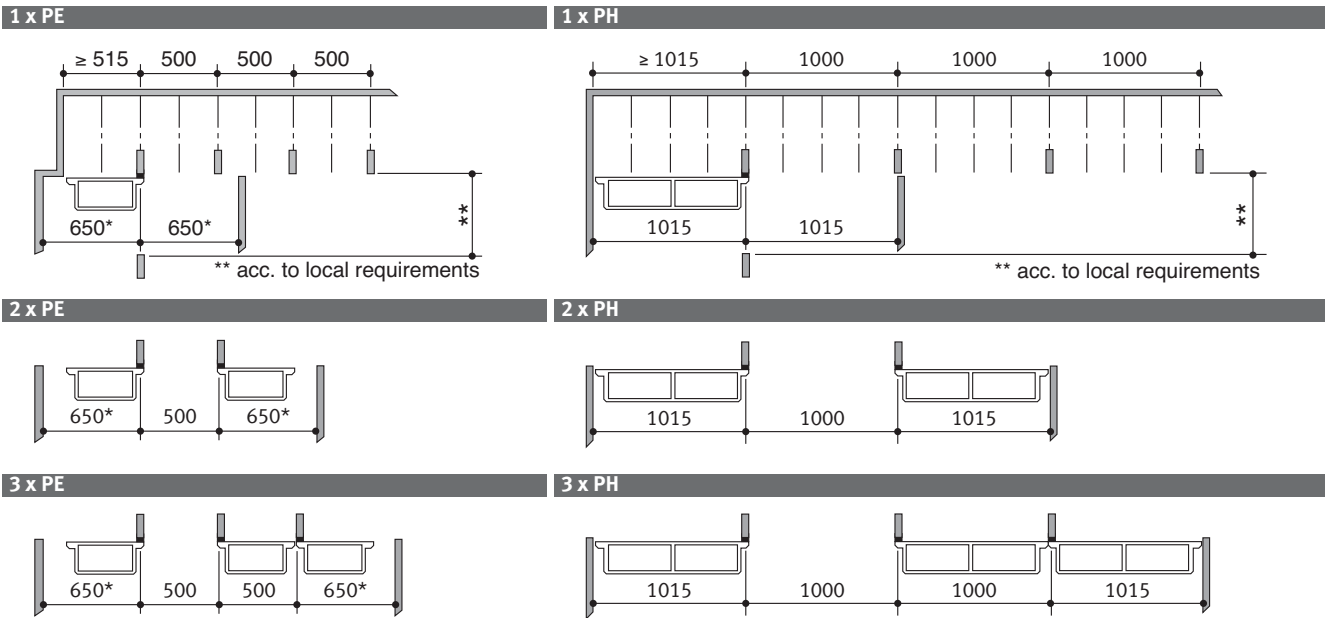

* = Recommendation

Combination:

At a length of 40 m up to 5 pallets can be arranged as group should their shifting path overlap. In this case the operating elements must be within a distance of 10 m of a possible point of contact between two pallets.

Above-Floor Drive (Drive S)

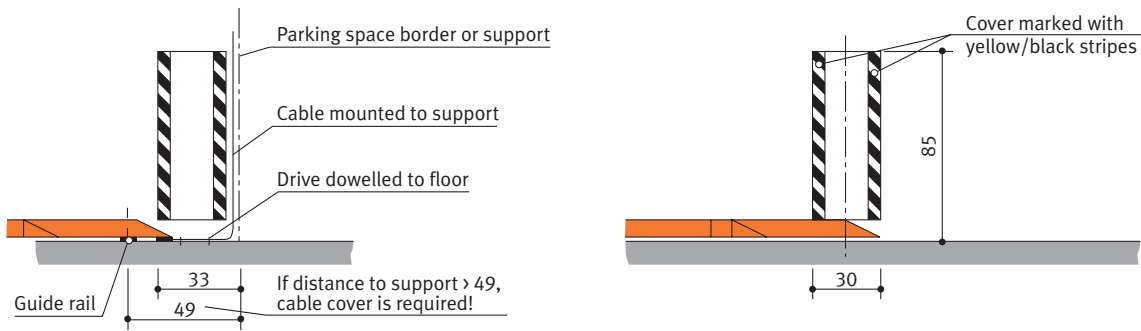

Evenness and Tolerances (Abstract from DIN 18 202, Table 3)

The safety distance between the lower flange of the platforms and the garage ground must therefore not exceed 2 cm. To adhere to the safety regulations and VdTÜV/CEOC recommendations and to get the necessary even ground, the tolerances of evenness according to DIN 18202, table 3, line 3, must not be exceeded. Therefore exact levelling of the ground by the client is essential.

| Column | 1 | 2 | 3 | 4 | 5 | 6 |
|--------|---|---|---|----|----|----|
| Line | Reference | Vertical measurement as limits in mm with measuring points distances in m to* | | | | |
| | | 0,1 | 1 | 4 | 10 | 15 |
| 2 | Unfinished to surface of covers, subconcrete and subsoils for higher demands, e.g. as foundation for cast plaster floor, industrial soils, paving tiles and slabstone paving, compound floor paving. Finished surfaces for minor purposes, e.g. warehouses, cellar. | 5 | 8 | 12 | 15 | 20 |
| 3 | Finished grounds, e.g. floor pavement serving as foundation for coverings. Coverings, tile coverings, PVC flooring and glued coverings. | 2 | 4 | 10 | 12 | 15 |

* = Intermediate values are to be taken out the diagram and must be rounded-off to mm

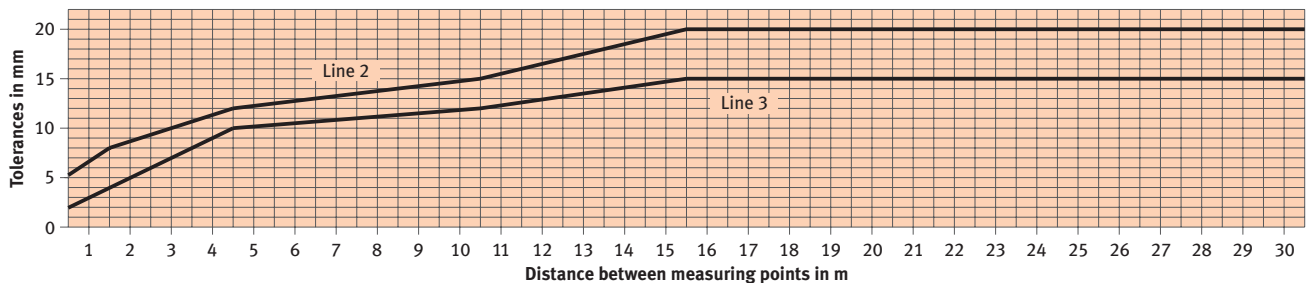

- Page 1
Dimensions
Car data
- Page 2
Examples
Drive
Evenness
- Page 3
Drive
Rails
Incline
- Page 4
Access
Electric
Technical
data
- Page 5
To be performed by the customer
Description

Longitudinal Pallets with Underfloor Drive (Drive U)

If the drive axis cannot be placed in front of a support the drive will be designed as underfloor drive.

Precondition: Drive axis located in parking space axis; recess in floor.

For arrangement of longitudinal pallets, see example:

2 x PE

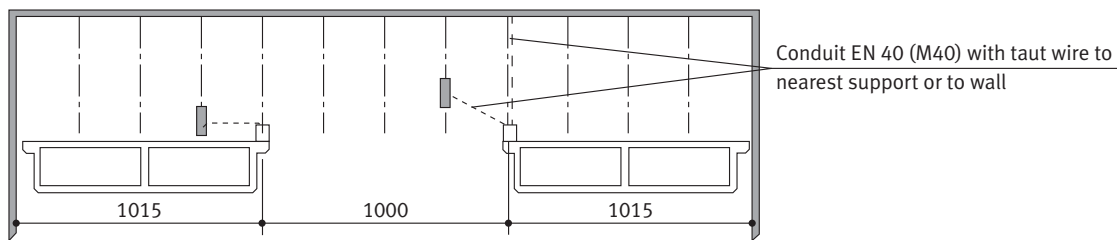

Underfloor Drive (Drive U)

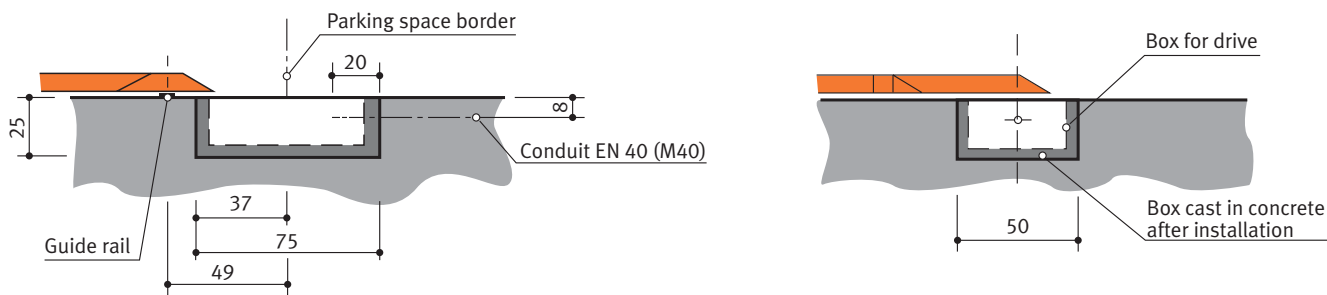

Rail System

Prior to using poured asphalt it is essential to consult Klaus!

PE und PH

Prior to floor pavement

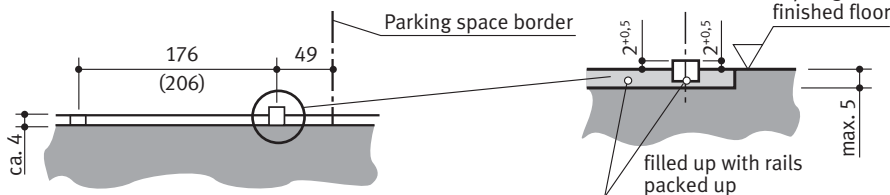

! Projection of the guide rail above top edge of finished floor is mandatory on both sides of the rail including the level for the drive!

In recess (RR = running rail; GR = guide rail)

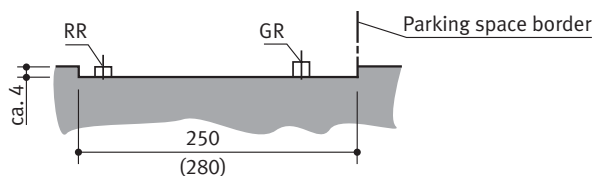

() = Dimensions in brackets for Exclusive type

On finished floor

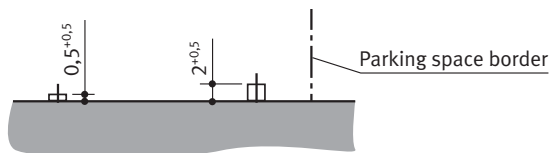

! The rails are dowelled directly onto the top edge of the finished floor.

Drill hole depth: approx. 9 cm.

Tolerances for the evenness must be strictly complied with in accordance with DIN (= German Industrial Standard) No. 18202, table 3, line 3!

Incline

PE und PH

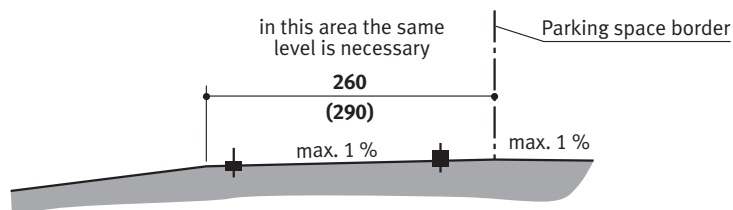

() = Dimensions in brackets for Exclusive type

- Page 1
Dimensions
Car data
- Page 2
Examples
Drive
Evenness
- Page 3
Drive
Rails
Incline
- Page 4
Access
Electric
Technical
data
- Page 5
To be performed
by the customer
Description

Accessing Standard Parking Spaces (for example No. 6)

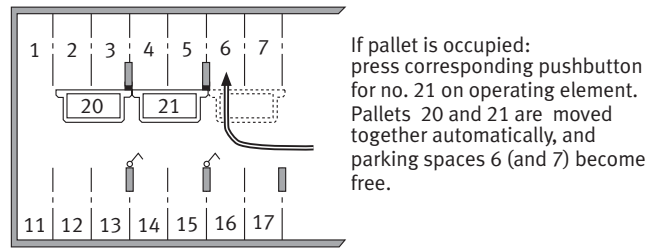
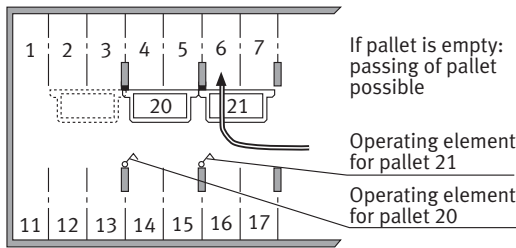

Accessing the Pallet Parking Spaces

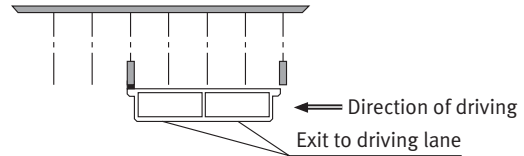
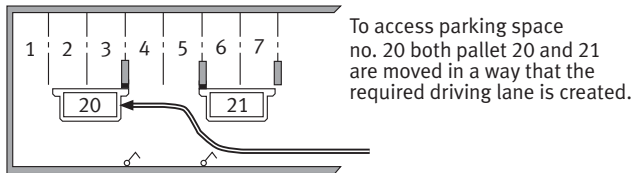

Note: PE at End of Driving Lane

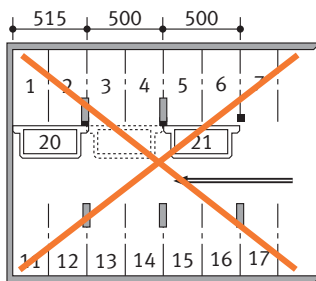

Unfavourable!!

Parking spaces 1, 2, 11, 12 can only be accessed unfavourably since both driving and turning range are strongly restricted.

Solution: Dislocate support or drive

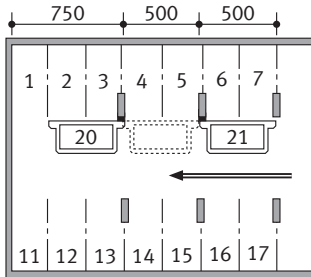

Solution: Use of PH

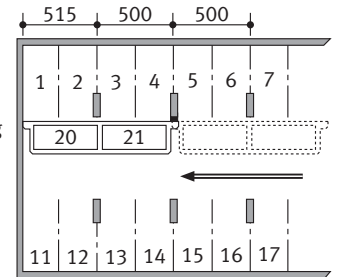

Note: Dislocated Parking Spaces

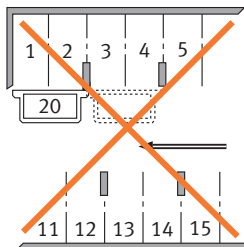

Not possible!!

Parking space 12 cannot be accessed if parking space 20 is occupied.
Reason:
Axes of opposite parking spaces are offset.

Makeshift: One-sided pallet extension

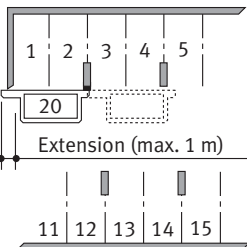

Makeshift: Travelling drive (drive D)

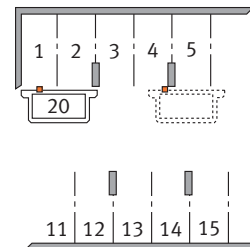

Travelling drive:
Drive D on the pallet
allows longer travel
path. Power supply
via trailing cable.
Special guide rail.
Warning:
Pallet not accessible
within range of
drive!

Electrical installation

Electrical supply/Control system

The customer must provide a supply of 5 x 2.5 mm² (3 PH+N+PE) to the electric cabinet (larger systems may require larger cross sections).

Proposals for position of control box and operating element are specified in the floor plans provided by Klaus Multiparking.

Operation

Operation via operating element with automatic reset function (two pushbuttons for left/right movement).

Technical data

Range of application

Generally, this parking system is not suited for short-time parkers (temporary parkers). Please do not hesitate to contact your local KLAUS agency for further assistance.

Available documents

- maintenance offer/contract
- declaration of conformity

Corrosion protection

See separate sheet regarding corrosion protection.

Noise emission

Ball bearing of the rollers provide a low sound level.

Environmental conditions

Environmental conditions for the area of multiparking systems:
Temperature range -10 to +40° C. Relative humidity 50% at a maximum outside temperature of +40° C.

On block operation

Parking pallets must only be operated on block if the operator's stand is not more than 10 m from the platform edges that are to be operated on block, and if it is installed at least 1.60 m above garage floor.

Page 1
Dimensions
Car data

Page 2
Examples
Drive
Evenness

Page 3
Drive
Rails
Incline

Page 4
Access
Electric
Technical
data

Page 5
To be performed by the customer
Description

To be performed by the customer

Numbering of parking spaces

Consecutive numbering of pallet parking spaces

Building services

Lighting, ventilation, fire extinguishing and fire alarm systems.

Electrical supply to the control box

Electrical supply 5 x 2.5 mm² (3 PH+N+PE) with lockable main switch to control box.

Main fuse:

3 x fuse 10 A (slow) or circuit breaker 3 x 10 A (trigger characteristic K or C).

5 or more pallets:

3 x fuse 16 A (slow) or circuit breaker 3 x 16 A (trigger characteristic K or C).

Electrical supply to the control box must be provided by the customer during installation. The functionality can be checked on site by our fitters together with the electrician. If this cannot be done during installation for some reason for which the customer is responsible, the customer must commission an electrician at his own expense and risk.

Marking

Any additional yellow-black markings on the platform edges according to ISO 3864.

Main switch

Lockable main switch per electric cabinet. The lockable main switch is to be mounted directly next to the control cabinet.

Floor

Flooring structure in accordance with our instructions, please see page 2 (recesses, tolerances for the evenness of the driving lane must adhere to DIN 18202, sheet 3, line 3.

Packing up of rail system (and box for drive U) with cement floor for the whole length.

Conduit EN 40 (M40) with taut wire to underfloor drive.

If the following are not included in the quotation, they will also have to be provided / paid for by the customer:

- Costs for final technical approval by an authorized body
- Main switch

Description

General description

Multiparking system for parking 1 or 2 vehicles.

Dimensions are in accordance with the respective underlying height and width dimensions.

Parking pallets, which can be moved lengthwise are installed in the driving lane of underground garages. These parking pallets make it possible to achieve additional parking spaces in the driving lane, which is generally only used for maneuvering vehicles.

The parking pallets can be driven on if vacant, or moved if occupied by a car when accessing parking spaces located in the back.

This operation uses dead man's control safety mechanism. Therefore, the operating elements are generally mounted to the opposite supports and the parking pallets and parking spaces arranged by the controller can be seen.

Operating instructions are permanently mounted to each operating station in a clearly visible location.

These parking pallets are available in the following designs:

Type PE: 1 passenger car

Type PH: 2 passenger cars in a row

Parking pallet consisting of:

- Sloped steel frames with supported low-noise track and guide rollers
- Crossbeams
- Platform profiles (cover plate)
- Positioning aids
- Small parts, etc.
- Pallet height: approximately 10 cm above finished floor

Floor-mounted drive:

- Base plate mounted to the ground with geared motor
- Limit switch and housing
- The housing also serves as safety mechanism. The load transmission is carried out via a high-tension chain located in a U-profile which is open facing outwards. This chain is looped around two chain wheels and driven by the motor.

Below-floor drive:

This drive unit is mounted in a floor recess which must be built by the customer. This drive consists of:

- 1 geared motor
- Chain wheels
- Limit switch
- Fully mounted in a stable below-floor housing with cover
- The load transmission is carried out identically to the "floor-mounted drive"

Moving drive (special):

- Drive unit mounted to the parking pallet
- Power is supplied via a drag-line cable (or via contact lines in exceptional cases)
- The load transmission is carried out using a chain, which is inlaid in a special rail (double rail)

Rail system consisting of:

- Profiles mounted to the floor, which must be embedded in concrete by the customer based on our specifications
- The guide rails protrude 20 mm above finished floor, thus ensuring safe guiding when shifting the pallets
- The rail system can be fastened to the finished floor in exceptional cases and in the event of adequate evenness of the driving lane in the movement area of the parking pallets (see "Floor" in the chapter "To be performed by the customer")

Electrical equipment consisting of:

- Operating device with 2 buttons (right/left)
- Emergency Stop
- Control box
- Blinking lights
- Various cables with accessories

Control system:

- The parking pallets are operated using a push-button with corresponding direction definition in dead man's control
- Limit switches stop the parking pallets when the maximum movement distance has been reached
- Warning lights blink during movement
- The electrical wiring originates in the control box

We reserve the right to change this specification without further notice

The Klaus company reserves the right in the course of technical progress to use newer or other technologies, systems, processes, procedures or standards in the fulfillment of their obligations other than those originally offered provided the customer derives no disadvantage from their so doing.