

- Page 1
Section
Dimensions
Car data
- Page 2
Width
dimensions
- Seite 3
Width
dimensions
Rails
Tolerances
- Seite 4
Approach
Load plan
Free spaces
Function
- Page 5
Electric data
Techn. data
To be performed
by the customer
- Page 6
Description

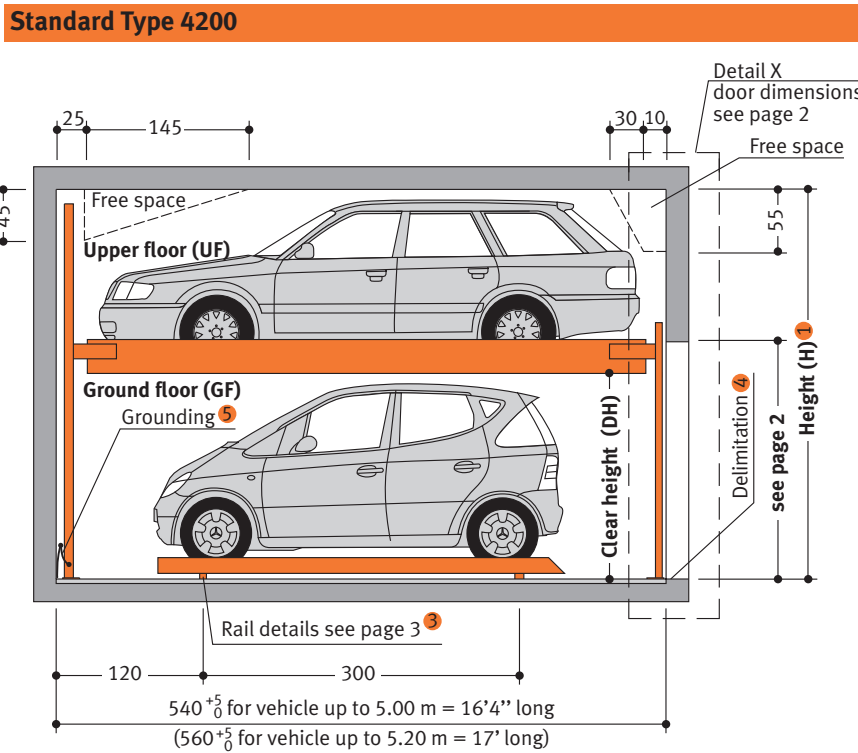

Product Data
TrendVario
4200

CE CONFORMITY

Loadable up to 2,600 kg

Single parking spaces can also be upgraded to handle heavier loads at a later date!

Number of parking spaces:
min. 3 to max. 29 vehicles

Dimensions: 2
All space requirements are minimum finished dimensions. Tolerances for space requirements $\pm 3/0$. Dimensions in cm.

Type	DH*	H
4200	160	330
4200	175	345
4200	180	370
4200	185	380
4200	210	405
4200	215	440

* = without car

Suitable for:
Standard passenger car, station wagon/ Van. Height and length according to contour.

Compact Type 4200

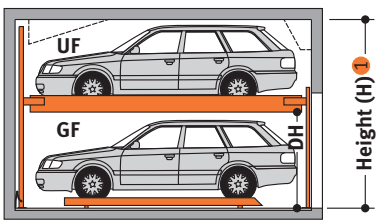

Exclusive Type 4200

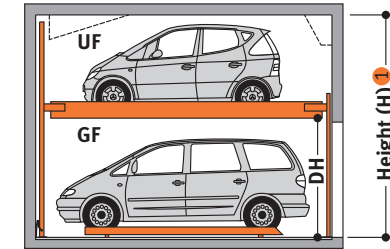

Type	DH	H	car height	
			UF	GF
4200	160	330	150	150
4200	175	345	150	165
4200	180	370	170	170
4200	185	380	175	175
4200	210	405	175	200
4200	215	440	205	205

width	190 cm
weight 6	max. 2000/2600 kg
wheel load	max. 500/650 kg

Notes

- 1 If height H is larger, vehicles with the maximum height as applicable for the GF can be parked on the UF, otherwise there will be free space available on the ceiling.
- 2 In order to meet the minimum finished dimensions the tolerances according to VOB, part C (DIN 18330 and 18331) as well as the DIN 18202 must be observed.
- 3 Tolerances for the evenness of the carriageway (floor) must be strictly complied with in accordance with DIN (=German Industrial Standard) No. 18202, chart 3, line 3.
- 4 On the standard version without door, a 10 cm wide yellow-black markings compliant to ISO 3864 must be applied by the customer to the edge of the platform in the access area to mark the danger zone in compliance with DIN EN 14 010 (see »Width Dimensions – Standard without Door« page 2).
- 5 Potential equalization from foundation grounding connection to system (provided by the customer).
- 6 Maximum load of 2,600 kg for extra charge.

General notes

If sprinklers are required make sure to provide the necessary free spaces during the planning stage.

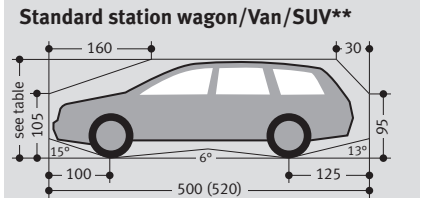
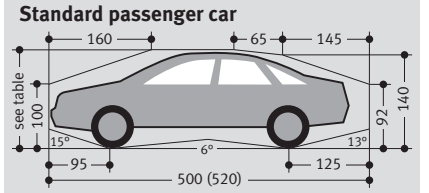

Standard passenger car, station wagon/ Van/ SUV are vehicles without any sports options such as spoilers, low-profile tyres etc.
** = Make sure to observe the weights and dimensions!

KLAUS
multiparking

Klaus Multiparking GmbH
Hermann-Krum-Straße 2
D-88319 Aitrach

Phone **+49-75 65-5 08-0**
Fax **+49-75 65-5 08-88**
E-Mail **info@multiparking.com**
Internet **www.multiparking.com**

Page 1
Section
Dimensions
Car data

Page 2
Width
dimensions

Seite 3
Width
dimensions
Rails
Tolerances

Seite 4
Approach
Load plan
Free spaces
Function

Page 5
Electric data
To be performed
by the customer

Page 6
Description

Widths – Detail X for garages without sliding doors (Standard)

Lowering of the platforms: via hold-to-run-device, lifting and shifting of the platforms: automatically.

Without door

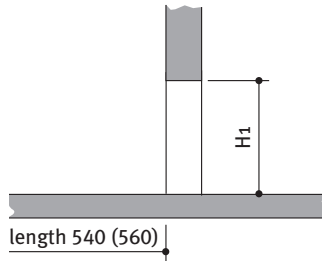

Type	H	DH	H1
4200	330	160	210
4200	345	175	210
4200	370	180	210
4200	380	185	210
4200	405	210	220
4200	440	215	225

Columns per each grid unit

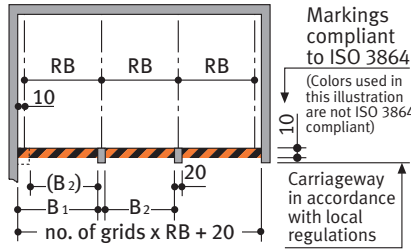

usable platform width	grid unit width RB**	B1	B2
UF: 230 * GF: 220	250	250	230
UF: 240 GF: 230	260	260	240
UF: 250 GF: 240	270	270	250
UF: 260 GF: 250	280	280	260
UF: 270 GF: 260	290	290	270

Columns every second grid unit

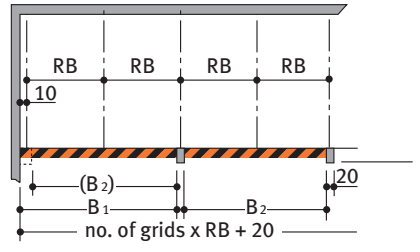

usable platform width	grid unit width RB**	B1	B2
UF: 230 * GF: 220	250	500	480
UF: 240 GF: 230	260	520	500
UF: 250 GF: 240	270	540	520
UF: 260 GF: 250	280	560	540
UF: 270 GF: 260	290	580	560

Widths – Detail X for garages with sliding doors (special model)

Lowering, lifting and shifting of the platforms: automatically.

Sliding door behind columns

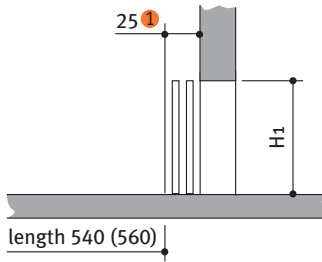

Type	H	DH	H1
4200	330	160	210
4200	345	175	210
4200	370	180	210
4200	380	185	210
4200	405	210	220
4200	440	215	225

Sliding door between columns

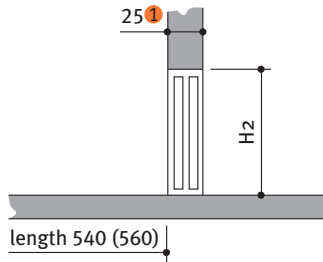

Type	H	DH	H2
4200	330	160	220
4200	345	175	220
4200	370	180	220
4200	380	185	220
4200	405	210	230
4200	440	215	235

Sliding door in front of columns

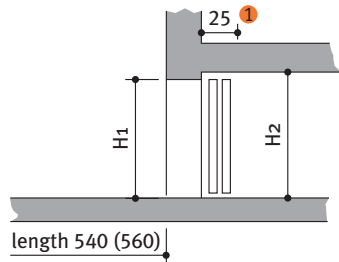

Type	H	DH	H1	H2
4200	330	160	210	220
4200	345	175	210	220
4200	370	180	210	220
4200	380	185	210	220
4200	405	210	220	230
4200	440	215	225	235

Columns per each grid unit

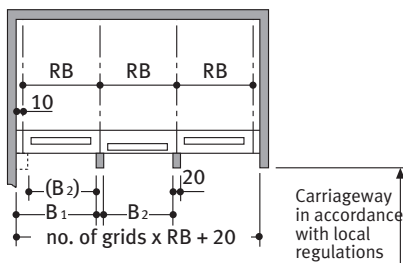

usable platform width	grid unit width RB**	B1	B2
UF: 230 * GF: 220	250	250	230
UF: 240 GF: 230	260	260	240
UF: 250 GF: 240	270	270	250
UF: 260 GF: 250	280	280	260
UF: 270 GF: 260	290	290	270

Columns per each grid unit

Not available!

Columns per each grid unit

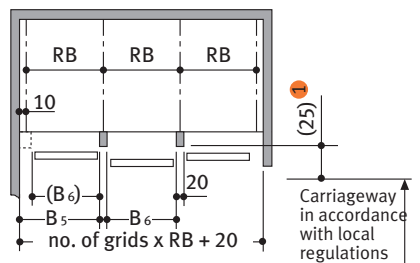

usable platform width	grid unit width RB**	B5	B6
UF: 230 * GF: 220	250	250	230
UF: 240 GF: 230	260	260	240
UF: 250 GF: 240	270	270	250
UF: 260 GF: 250	280	280	260
UF: 270 GF: 260	290	290	270

Columns every second grid unit

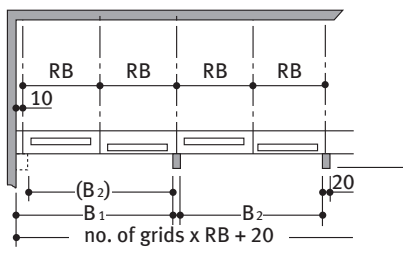

usable platform width	grid unit width RB**	B1	B2
UF: 230 * GF: 220	250	500	480
UF: 240 GF: 230	260	520	500
UF: 250 GF: 240	270	540	520
UF: 260 GF: 250	280	560	540
UF: 270 GF: 260	290	580	560

Columns every second grid unit

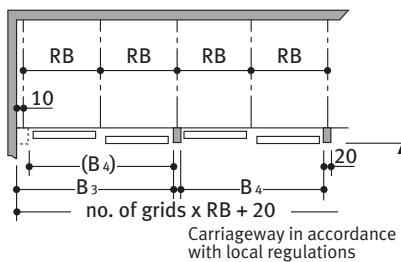

usable platform width	grid unit width RB**	B3	B4
UF: 230 * GF: 220	250	500	480
UF: 240 GF: 230	260	520	500
UF: 250 GF: 240	270	540	520
UF: 260 GF: 250	280	560	540
UF: 270 GF: 260	290	580	560

Columns every second grid unit

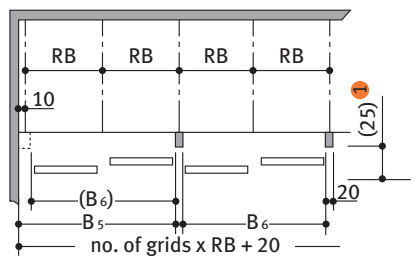

usable platform width	grid unit width RB**	B5	B6
UF: 230 * GF: 220	250	500	480
UF: 240 GF: 230	260	520	500
UF: 250 GF: 240	270	540	520
UF: 260 GF: 250	280	560	540
UF: 270 GF: 260	290	580	560

① = Only applies to manually operated doors. The electrically driven doors must have 35 cm.

* = Standard width (parking space width 230 cm)

** = Grid unit width **must** strictly conform to dimensions quoted



End parking spaces are generally more difficult to drive into. Therefore we recommend for end parking spaces our wider platforms. Parking on standard width platforms with larger vehicles may make getting into and out of the vehicle difficult. This depends on type of vehicle, approach and above all on the individual driver's skill.

- Page 1
Section
Dimensions
Car data
- Page 2
Width
dimensions
- Seite 3
Width
dimensions
Rails
Tolerances
- Seite 4
Approach
Load plan
Free spaces
Function
- Page 5
Electric data
Techn. data
To be performed
by the customer
- Page 6
Description

Widths – Detail X for garages with roll doors

Roll door behind columns

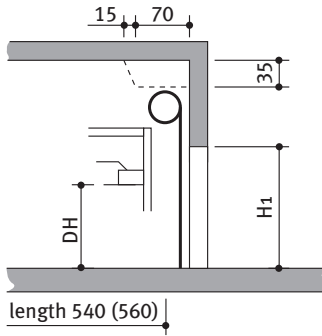

Columns per each grid unit

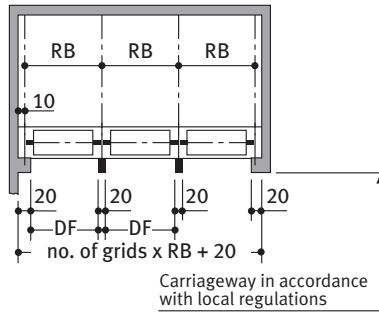

length 540 (560)

Type	H	DH	H1	roll door height
4200	330	160	210	263
4200	345	175	210	263
4200	370	180	220	263
4200	380	185	210	263
4200	405	210	220	300
4200	440	215	225	300

usable platform width	grid unit width RB**	door entrance width DF	
UF: 230 *	GF: 220	250	230
UF: 240	GF: 230	260	240
UF: 250	GF: 240	270	250
UF: 260	GF: 250	280	260
UF: 270	GF: 260	290	270

* = Standard width (parking space width 230 cm)

** = Grid unit width **must** strictly conform to dimensions quoted

! End parking spaces are generally more difficult to drive into. Therefore we recommended for end parking spaces our wider platforms. Parking on standard width platforms with larger vehicles may make getting into and out of the vehicle difficult. This depends on type of vehicle, approach and above all on the individual driver's skill.

Rail system

Dependent upon the structural conditions of the garage, several different options are available for installation of the rails:

When executing the carriageway, according to raw bottom floor combined with a cement screed or
When executing the carriageway with recesses for the rails:

- The set-up of the rails amounts to 3 cm (height of floor screed 4 cm)
- After the rails have eventually been laid, the area under the rails must be topped up with concrete by the customer

Exact evenness of the carriageway:

- When exact evenness of the carriageway has successfully been accomplished, the rails may be dowelled onto it

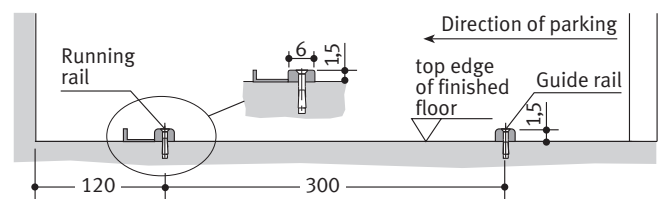
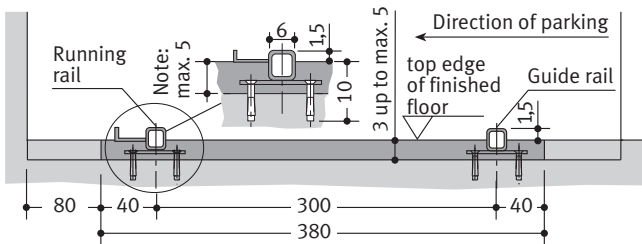

Note: Tolerances for the evenness of the carriageway must be strictly complied with in accordance with DIN (= German Industrial Standard) No. 18202, chart 3, line 3.

Evenness and Tolerances (abstract from DIN 18202, table 3)

The distance between the lower flange of the platforms and the garage ground must therefore not exceed 2 cm. To adhere to the safety regulations and DIN EN 14 010 recommendations and to get the necessary even ground, the tolerances of evenness to DIN 18202, table 3, line 3, must not be exceeded. Therefore exact levelling of the ground by the client is essential.

Column	1	2	3	4	5	6
Line	Reference	Vertical measurement as limits in mm with measuring points distances in m to*				
2	Unfinished to surface of covers, subconcrete and subsoils for higher demands, e.g. as foundation for cast plaster floor, industrial soils, paving tiles and slabstone paving, compound floor paving. Finished surfaces for minor purposes, e.g. warehouses, cellar.	0.1	1	4	10	15
3	Finished grounds, e.g. floor pavement serving as foundation for coverings. Coverings, tile coverings, PVC flooring and glued coverings.	5	8	12	15	20
		2	4	10	12	15

* = Intermediate values are to be taken out the diagram and must be rounded-off to mm

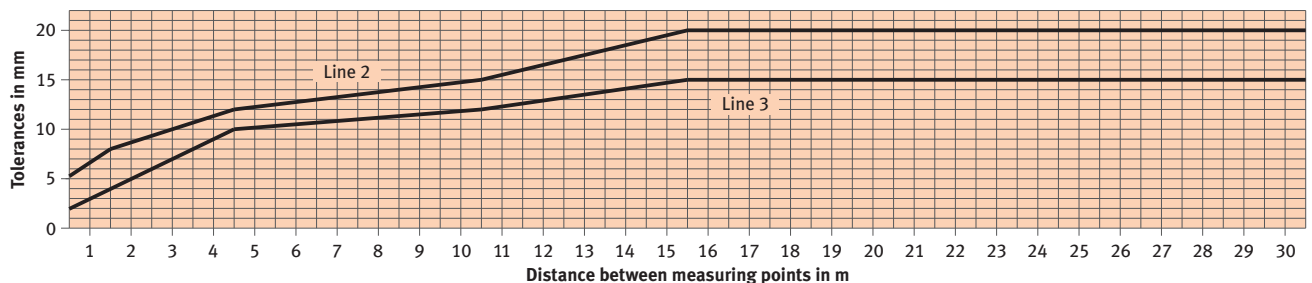

- Page 1
Section
Dimensions
Car data
- Page 2
Width
Dimensions
- Seite 3
Width
Dimensions
Rails
Tolerances
- Seite 4
Approach
Load plan
Free spaces
Function
- Page 5
Electric data
Techn. data
To be performed
by the customer
- Page 6
Description

Approach

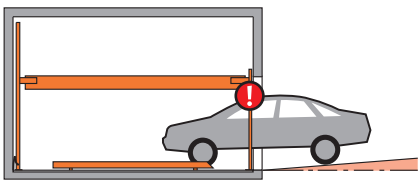

maximum descending slope 3 %

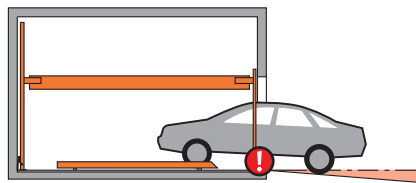

maximum ascending slope 5 %

! The illustrated maximum approach angles must not be exceeded. Incorrect approach angles will cause serious manoeuvring & positioning problems on the parking system for which the local agency of Klaus accepts no responsibility.

Load plan

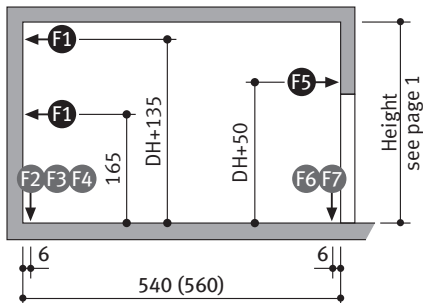

DH: see page 1
The dimensions for the points of support are rounded values. If the exact position is required, please contact Klaus Multiparking.

Load plan – top view

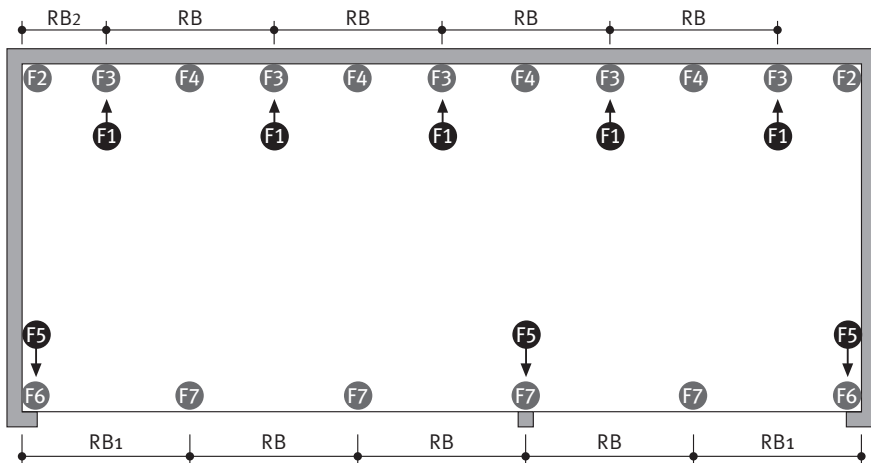

usable platform width	RB	RB1	RB2
UF: 230 *	250	260	135
UF: 240	260	270	140
UF: 250	270	280	145
UF: 260	280	290	150
UF: 270	290	300	155

platform load	F1	F2	F3	F4	F5	F6	F7
2000 kg	±2	-9	+38	-18	approx. +0,5	+9	+18
2600 kg	±2	-11	+41	-22	approx. +0,5	+12	+24

* = Standard width

Forces in kN

! The system is dowelled to floor and walls. The drilling depth in the floor is approx. 15 cm. The drilling depth in the walls is approx. 12 cm. Floor and walls are to be made of concrete (grade of concrete min. C20/25)!

Longitudinal free space; Standard parking space numbers; Denomination

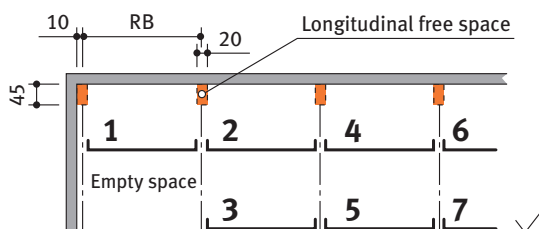

Moving direction

Upper floor

Ground floor

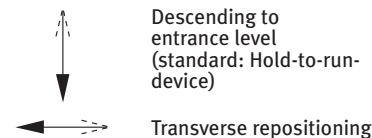

Function of the Parking Automat

e.g. for parking space No. 4: Check first that all doors are closed, then select No. 4 on operating panel.

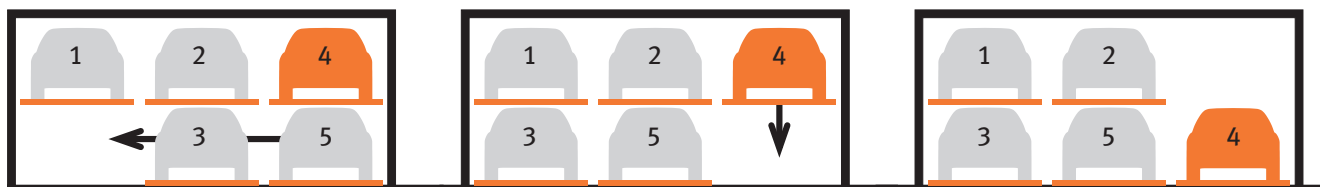

For driving the vehicle off platform No. 4 the ground floor parking platforms are shifted to the left.

The empty space is now below the vehicle which shall be driven off the platform. The platform No. 4 will be lowered.

The vehicle on platform No. 4 can now be driven off the platform.

Page 1
Section
Dimensions
Car data

Page 2
Width
Dimensions

Seite 3
Width
Dimensions
Rails
Tolerances

Seite 4
Approach
Load plan
Free spaces
Function

Page 5
Electric data
Techn. data
To be performed
by the customer

Page 6
Description

Electrical data

Control box

The control box must be accessible at all times from outside!

Dimensions approx. 100 x 100 x 30 cm.

Cutting through of wall from control box to parking system (contact the local agency of Klaus Multiparking for clarification)

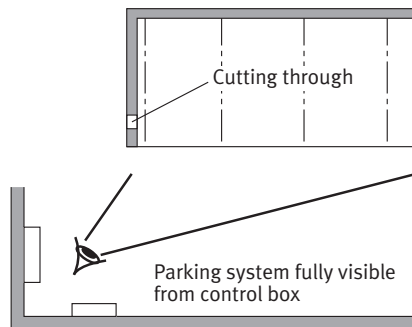

Technical data

Range of application

Generally, this parking system is not suited for short-time parkers (temporary parkers). Please do not hesitate to contact your local KLAUS agency for further assistance.

Available documents

- wall recess plans
- maintenance offer/contract
- declaration of conformity
- test sheet on airborne and slid-borne sound

Corrosion protection

See separate sheet regarding corrosion protection.

Environmental conditions

Environmental conditions for the area of multiparking systems: Temperature range -10 to $+40^{\circ}\text{C}$. Relative humidity 50% at a maximum outside temperature of $+40^{\circ}\text{C}$. If lifting or lowering times are specified, they refer to an environmental temperature of $+10^{\circ}\text{C}$ and with the system set up directly next to the hydraulic unit. At lower temperatures or with longer hydraulic lines, these times increase.

Electrically driven doors

In accordance with ZH 1/494 commercially used power-driven doors must be subjected to annual inspections. We urgently recommend concluding a maintenance agreement that includes this service for the entire system.

Numbering

The standard numbering of the parking spaces is to be taken from page 3. Different numbering is only possible at extra cost. Please take note of the following specifications:

In general, the empty space must be arranged to the left. The numbers must be provided 8 – 10 weeks before the delivery date.

To be performed by the customer

Safety fences

Any constraints that may be necessary according to DIN EN ISO 13857 in order to provide protection for the park pits for pathways directly in front, next to or behind the unit. This is also valid during construction.

Numbering of parking spaces

Consecutive numbering of parking spaces.

Building services

Lighting, ventilation, fire extinguishing and fire alarm systems.

Marking

According to DIN EN 14 010, a warning that identifies this danger area must be placed in the entrance area that conforms to ISO 3864. This must be done according to EN 92/58/EWG for systems without a pit 10 cm from the edge of the platform.

Wall cuttings

Any necessary wall cuttings.

Door shields

Door shields that may be necessary. If desired, they can be ordered from Klaus Multiparking for an additional charge.

Electrical supply to the control box / Foundation earth connector

Suitable electrical supply $5 \times 2.5 \text{ mm}^2$ (3 PH+N+PE) to control box with mains fuse $3 \times 16 \text{ A}$ slow or over-current cut-out $3 \times 16 \text{ A}$ trigger characteristic K or C.

Suitable electrical supply to the control box must be provided by the customer during installation. The functionality can be monitored on site by our fitters together with the electrician. If this cannot be done during installation for some reason for which the customer is responsible, the customer must commission an electrician at their own expense and risk.

In accordance with DIN EN 60204 (Safety of Machinery. Electrical Equipment), grounding of the steel structure is necessary, provided by the customer (distance between grounding max. 10 m).

Operating device

Easy-to-survey positioning (e.g. on column).

Protection against unauthorized use.

May also be recessed in wall if required.

Sound insulation

According to DIN 4109 (Sound insulation in buildings), para. 4, annotation 4, Klaus Multiparkers are part of the building services (garage systems).

Normal sound insulation:

DIN 4109, para. 4, Sound insulation against noises from building services.

Table 4 in para. 4.1 contains the permissible sound level values emitted from building services for personal living and working areas. According to line 2 the maximum sound level in personal living and working areas must not exceed 30 dB (A).

Noises created by users are not subject to the requirements (see table 4, DIN 4109).

The following measures are to be taken to comply with this value:

- Sound protection package according to offer/order (Klaus Multiparking GmbH)
- Minimum sound insulation of building $R'_w = 57 \text{ dB}$ (to be provided by customer)

Increased sound insulation (special agreement):

DIN 4109, Amendment 2, Information on planning and execution, proposals for increased sound insulation.

Agreement: Maximum sound level in personal living and working areas 25 dB (A). *Noises created by users are not subject to the requirements (see table 4, DIN 4109).*

The following measures are to be taken to comply with this value:

- Sound protection package according to offer/order (Klaus Multiparking GmbH)
- Minimum sound insulation of building $R'_w = 62 \text{ dB}$ (to be provided by customer)

Note: User noises are noises created by individual users in our Multiparking systems. These can be noises from accessing the platforms, slamming of vehicle doors, motor and brake noises.

Electrical supply to the control box / Foundation earth connector

Suitable electrical supply to the control box must be provided by the customer during installation. The functionality can be monitored on site by our fitters together with the electrician. If this cannot be done during installation for some reason for which the customer is responsible, the customer must commission an electrician at their own expense and risk.

In accordance with DIN EN 60204 (Safety of Machinery. Electrical Equipment), grounding of the steel structure is necessary, provided by the customer (distance between grounding max. 10 m).

Rails

A bed should be installed and concrete should be poured around the rails installed by the manufacturer throughout their entire length.

Tolerances

The tolerances for levelness of the driving surface must conform to DIN 18202, tab. 3, line 3.

If the following are not included in the quotation, they will also have to be provided / paid for by the customer:

- Costs for final technical approval by an authorized body

Description

General description

Multiparking system providing independent parking spaces for cars, one on top of the other and side by side.

Dimensions are in accordance with the underlying dimensions of height and width.

The parking bays are accessed horizontally (installation deviation $\pm 1\%$).

Along the complete width of the parking automat an approach lane (driving lane in accordance with local regulations) must be available.

Parking spaces are arranged on two different levels, one level on top of the other.

The platforms of the upper floor (UF) are moved vertically, the platforms on the ground floor (GF) horizontally. At approach level (GF) there is always one parking space less available. This vacant space is used for shifting the ground floor (GF) parking spaces sideways, thus enabling the upper platform (UF) parking space located above to be lowered to approach/ground level. Consequently, a unit of three parking spaces (1 on the ground floor, 2 on the upper floor) is the smallest unit available for this parking system.

The TrendVario 4200 allows parking of passenger cars and station wagons.

All necessary safety devices are installed. Safety devices mainly consist of chain monitoring system and locking levers for the upper platforms. Standard delivery is made without doors. The approach/entrance area to the parking automat is monitored via light barriers. If the light barrier is interrupted, the parking system stops moving instantly.

A steel framework mounted to the floor consisting of:

- Seriated supports
- Steel pillars with sliding platform supports
- Cross and longitudinal members
- running rails for the transversely movable ground floor (GF) platforms

Platforms consisting of:

- Side members
- Cross members
- Platform base sections
- 1 wheel stop (on the right per parking space)
- Screws, small parts, etc.

Lifting device for upper floor (UF) platforms:

- Hydraulic cylinder with solenoid valve
- Chain wheels
- Chains
- Limit switches
- The platforms are suspended on four points and guided along the supports using plastic sliding bearings

Drive unit of transversely movable platforms on the ground floor (GF):

- Gear motor with chain wheel
- Running and guide rollers (low-noise)
- Power supply via cable chain

Hydraulic unit consisting of:

- Hydraulic power unit (low-noise, installed onto a console with a rubber-bonded-to-metal mounting)
- Hydraulic oil reservoir
- Oil filling
- Internal geared wheel pump
- Pump holder
- Clutch
- 3-phase-AC-motor (3.0 kW, 230/400 V, 50 Hz)
- Motor circuit breaker
- Test manometer
- Pressure relief valve
- Hydraulic hoses (which reduce noise transmission onto the hydraulic pipe)

Hold-to-run-device (standard):

- Operation on a central control panel (operating device)
- All movements are latched automatically, except for downward movement of an OG parking space, for which the start button must be continually pressed
- Electric wiring is made from the electric cabinet by the manufacturer

Automatic control system (special design):

- Central control panel (operating device) used to select the desired parking space
- Here, it is necessary that a door system is installed in the entrance area. The doors are operated manually for a series system. If desired, this can also be done using electric motors.
- Electric wiring is made from the electric cabinet by the manufacturer

Laterally movable doors

Size

Sliding door, dimensions: approx. 2500 mm x 2000 mm (width x height).

Frame

- Frame construction with vertical centre stay bar made from extruded aluminium profiles (anodized, layer thickness approx. 20 μm)
- To open the doors a recessed grip is integrated in the aluminium profile.
- A rubber lip is used for the finishing of the closing edge to the building.

Standard door panel

Perforated steel plate

- Thickness 1 mm, RV 5/8, galvanized, layer thickness: approx. 20 μm
- Ventilation cross-section of the panel approx. 40 %
- Not suitable for outdoor garages

Alternative door panel

Perforated aluminium plate

- Thickness 2 mm, RV 5/8 E6/EV1, anodized, layer thickness: approx. 20 μm
- Ventilation cross-section of the panel approx. 40 %

Beaded steel plate

- Thickness 1 mm, galvanized, layer thickness: approx. 20 μm .
- additional power coating, layer thickness: approx. 25 μm on the outside and approx. 12 μm on the inside
- Colour options for the outside (building view):
RAL 1015 (light ivory), RAL 3003 (ruby),
RAL 5014 (pigeon blue), RAL 6005 (moss green),
RAL 7016 (charcoal grey), RAL 7035 (light grey),
RAL 7040 (window grey), RAL 8014 (sepia),
RAL 9006 (white aluminium), RAL 9016 (traffic white)
- Inside of the gates in light grey

Plain aluminium sheet

- Thickness 2 mm, E6/EV1, anodized, layer thickness: approx. 20 μm

Wooden panelling

- Nordic spruce in grade A
- vertical tongue and groove boards
- preimpregnated colourless

Laminated safety glass

- Laminated safety glass made from single pane safety glass 8/4 mm

Running rails

- The running gear of each doors consists of 2 twin-pair rolling gadgets, adjustable in height
- The running rails of the doors are fixed to brackets or the concrete lintel, or on a building-specific door suspension using ceiling fittings
- The guide consists of 2 plastic rollers mounted to a base plate, which is dowelled to the floor
- Running rails, ceiling fittings and guide roller base plate are hot-dip galvanized

Door actuation

Standard:

- Manually, i.e. the door is opened and closed by hand

Alternatively:

- Electric drive via electric motor mounted to the rail system at the turning point of the sliding doors. The drive pinion engages into the chain mounted to the door.

For safety reasons the movement of the platforms is always made behind locked doors. Position sensing, i.e. "door open" and "door closed" is effected by electric signalers.

Separation (if necessary):

- Upon request

Please note:

Door panels (on the side, cover for running rails, etc.) and door suspensions are not included in the standard version but can be delivered against surcharge as special equipment.

Important! Systems in outside areas (not an underground garage):

- If doors are not installed and the system can be freely accessed, this presents a danger, for example for children playing, for which we will not be held liable. If the TrendVario 4200 is ordered without doors, the customer expressly accepts full liability without limitations and frees the supplier from all claims. In individual cases, we reserve the right to not accept the order.
- Additionally, wetness, cold, ice and snow can cause problems when driving into and out of parking spaces. The weather conditions listed previously can cause lasting damage. Therefore, we recommend closed doors (not doors with wire mesh filling).

We reserve the right to change this specification without further notice

The Klaus company reserves the right in the course of technical progress to use newer or other technologies, systems, processes, procedures or standards in the fulfillment of their obligations other than those originally offered provided the customer derives no disadvantage from their so doing.